

# FIXED LITE WINDOW

*THERMALLY IMPROVED SUITE - INLINE FRAME*



Transoms (horizontal) or mullions (vertical) may be fitted within a single outer frame

Mitred corners enhance the window's clean appearance. All fixings are made from durable stainless steel

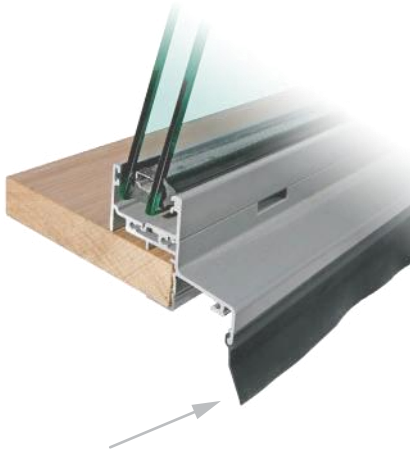

The optional sill flap can be easily fitted to the frame after installation

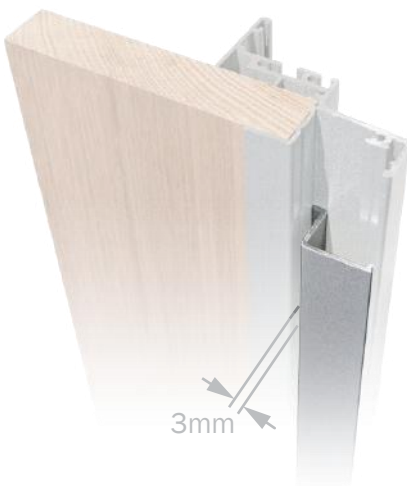

The optional snap-in frame closure has a 15 x 3mm slot for flashing insertion



All glass is installed into dual vinyl sided rebates, ensuring vibration free glazing. A co-extruded santoprene inner seal resists shrinkage & also assists with weatherproofing

The timber reveal sits inline with the frame's outer face, simplifying installation into a variety of wall types

# FIXED LITE WINDOW



## THERMALLY IMPROVED SUITE - INLINE FRAME

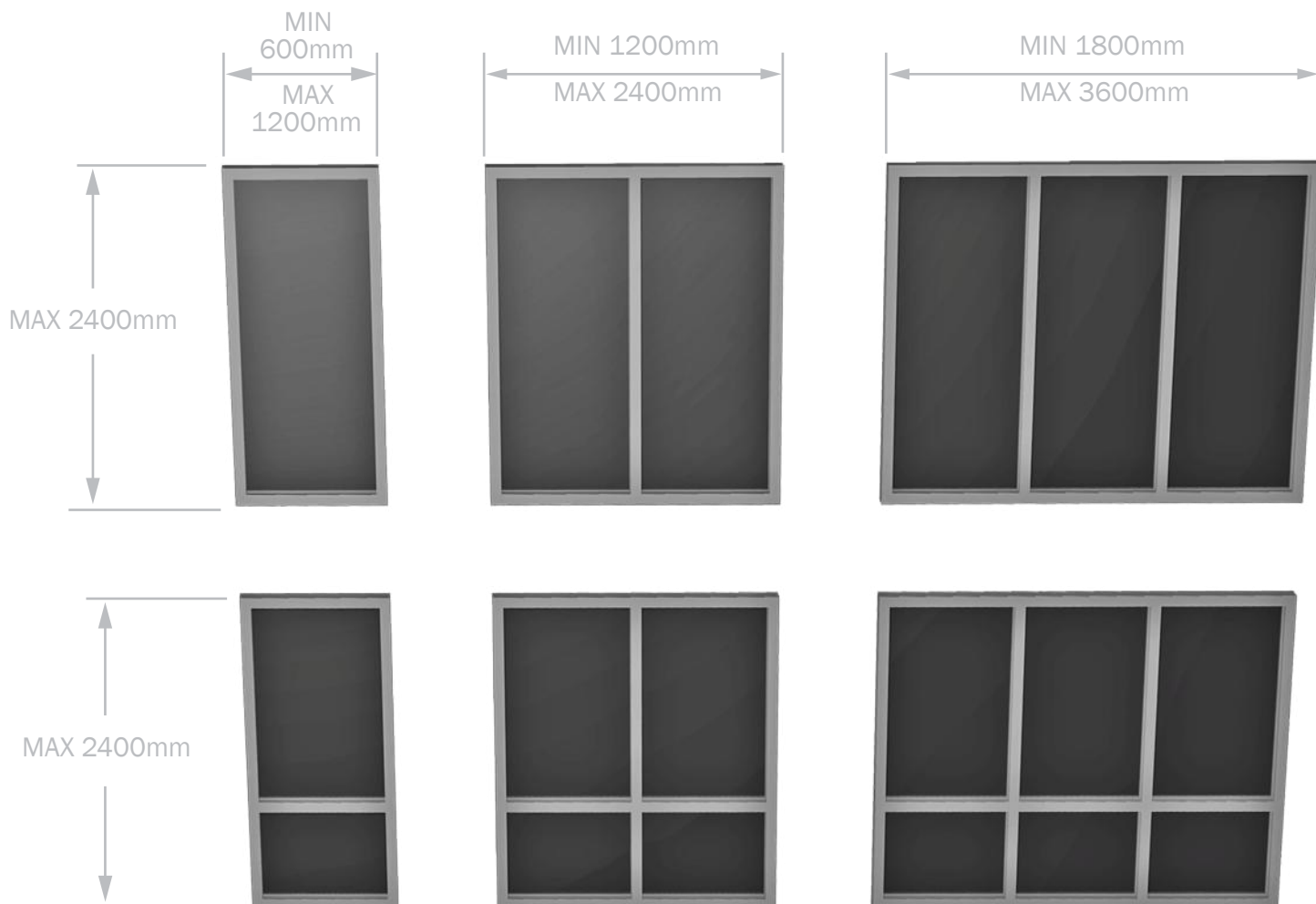

### NOTE:

ALL SIZES ARE TYPICAL RATHER THAN DEFINITIVE. FOR SIZES OUTSIDE OF THESE (incl. raked windows) PLEASE DISCUSS WITH YOUR VALLEY WINDOWS CONSULTANT

### Sizing

Window style & opening detail should be considered as viewed externally

Sizes indicated are the overall window size. Reveal is inline with outer frame dimension.

For Stud openings add 20mm to both height & width

### Glazing

Glazing strength to minimum N3 rating, as per AS4055 - 2006

Maximum double glazed panel thickness is 22mm

### Certification

Certified performance data including WERS ratings are available for this product on request

### Specify

Frame colour, configuration, height, width & overall depth

Optional: frame infill, sill flap, glass type